

ActiveVRS Suspension Seat

HEALTH CONCERNS

Your company's long-term health is directly affected by your drivers' exposure to whole body vibration (WBV). An eight-hour driving day or short-term exposure can result in:

- Muscle fatigue
- Discomfort
- Headache
- Motion sickness

Effects associated with regular exposure to WBV, or a week full of eight-hour driving days, include chronic health issues such as:

- Spinal disc disease
- Sciatic pain
- Herniated discs
- Low back pain
- Shortened career

Sears **ActiveVRS** Suspension Seat is proven to dramatically reduce WBV!

Protect Your Most Valuable Asset

Make the investment to promote driver health.



ActiveVRS
"Magnetic Ride Control"

SEARS
SEATING



ActiveVRS

"Magnetic Ride Control"

Reduce Exposure to WBV with the Sears Atlas II ActiveVRS Air Suspension Seat

The ActiveVRS Air suspension seat incorporates an active magnetic ride suspension system that greatly reduces vibrations to the operator versus normal passive air suspension seats.

The heart of the system consists of an active magnetic damper and a controller with an integrated position sensor.

How It Works:

The ActiveVRS suspension also contains an air reservoir (tank) that lowers the natural frequency to reduce the vibrations, such as "chatter," you get when driving on a road.

The suspension is calibrated when it leaves the factory, as we know the top and bottom of the suspension stroke (travel). As the suspension reacts to vibration inputs, the accelerometer (position sensor) senses the position of the stroke 500 times/second in relation to the top and bottom and how fast it is moving.

The controller then sends an electrical charge to the active magnetic damper. This electrical charge creates a magnetic field within the damper where it reacts with the magnetorheological (MR) fluid in the damper itself. The MR fluid changes viscosity under this field and stiffens the ride, utilizing metal particles contained within the MR fluid.

Through our ride testing, the ActiveVRS Magnetic Ride suspension system reduces vibrations to the operator 45% better than a regular passive air suspension.

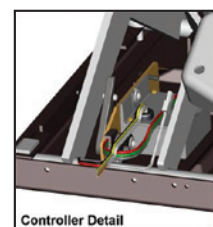
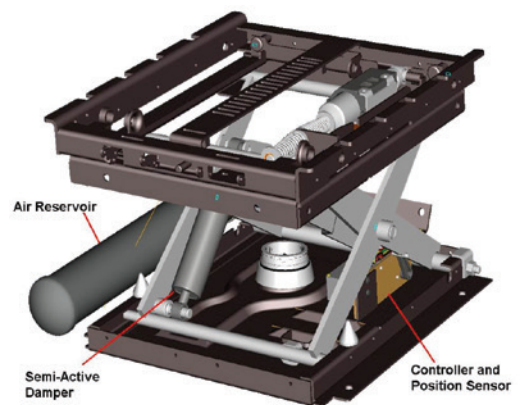
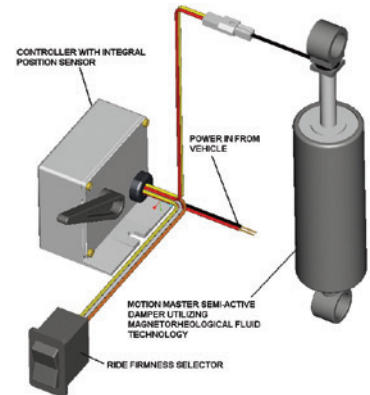

The University of Washington conducted a study of whole body vibration (WBV) exposures in long-haul truck drivers.

Results: The Sears Atlas II truck seat had 57% less vibration transmitted to the operator on the vertical acceleration axis than the competitive truck seats. For the vector sum of all accelerations, the Sears Atlas II truck seat shows a 20% reduction in total WBV over the competitive seats. **The Sears Atlas II ActiveVRS air suspension seat delivers improved vibration isolation over our Atlas II seat!**

Driver Recruitment and Retention

Having a Sears Atlas II ActiveVRS Magnetic Ride suspension seat in your cabs is a valuable driver recruitment tool and invaluable for driver retention. It can lower your drivers' exposure to WBV, resulting in reduced fatigue, more precise visual acuity, improved awareness of surroundings, faster response times and ultimately, improved driver health.

ActiveVRS Suspension Seat Offers:

- Improved vibration isolation, providing more comfort and less fatigue
- Active magnetic damper system utilizes controller with integrated position sensor to adjust stiffness of ride

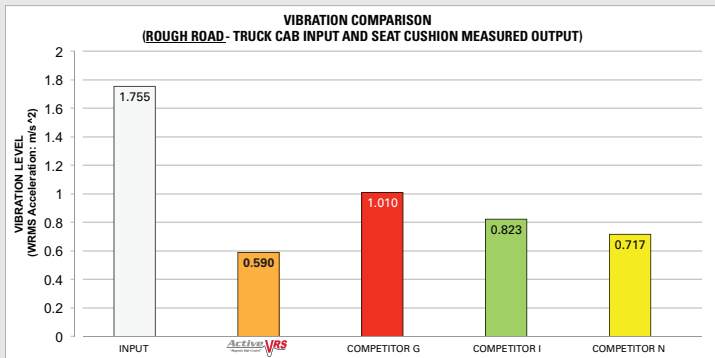

Under rough road conditions, the Sears Atlas II ActiveVRS Magnetic Ride System delivers from 18% to 42% improved vibration isolation compared to the competition.

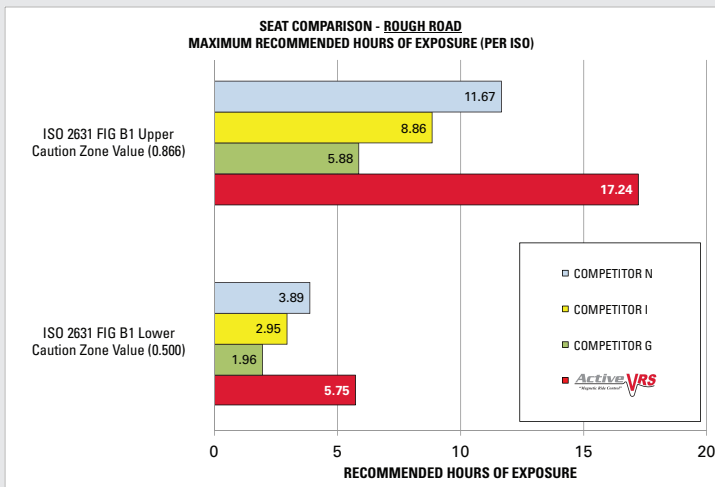

On a rough road and during a driver's normal eight (8) hour shift, the Sears Atlas II ActiveVRS Magnetic Ride System can lower the driver's exposure to WBV from 32%, up to 65% better than the competition.

Proven Performance and Driver Satisfaction

**David F. – 6'2", 275 lbs.
Avg. daily hours in seat: 10
Currently using Sears Atlas**

"The seat is easy to use and I never bottom out."

**Brian M. – 5'11", 300 lbs.
Avg. daily hours in seat: 10
Currently using Competitor G**

"Zero complaints about the ride with VRS. I'm not squirming around after four hours like I did with my old seat. Much better on my back and hips. No pain!"

**John B. – 6'3", 375 lbs.
Avg. daily hours in seat: 10 - 12
Currently using Competitor G**

"From controls to comfort, everything about the VRS is much better than my old seat. It's the first seat I've ever used that I haven't bottomed out on. This is way more comfortable than my last seat and I'm not as tired at the end of my shift."

Discover what makes the new *ActiveVRS* truck seats the “Best in Class” for ride and comfort



Contemporary Styling – New designed foam contours, new enhanced foam for greater comfort

Quad Chamber Air Lumbar – Dual bags each side of spine (no direct contact) provide less fatigue

3-1/2" foam on centerline for greater support

NEW – Easier to operate seat tilt and seat extension

Air Reservoir Bottle – Helps reduce vibrations from low frequency chatter



Back frame is contoured to the natural shape of the spine for less fatigue

New sleek valve control panel tucked along side of seat to eliminate cracking and breaking on panel

Separate 3-position switch to control firmness of **ActiveVRS** damper to operator preference

ActiveVRS Air Suspension provides more lateral stability, eliminates topping and bottoming, and automatically controls the ride.

On a rough road and during a driver’s normal eight (8) hour shift, the Sears *ActiveVRS* Magnetic Ride System can lower the driver’s exposure to whole body vibration (WBV) from 32%, up to 65% better than the competition. ***This translates to less fatigue and healthier operators.***



P.O. Box 3667 | Davenport, IA 52808
Phone: 800-553-3013 | Fax: 563-383-2819 | www.SearsSeating.com
©2016 Sears Manufacturing Company