

# SEARS SEATING

1602 Series

SHAPING *the future of seats today*



Multi - Innovationspreisgekrönte Sitze



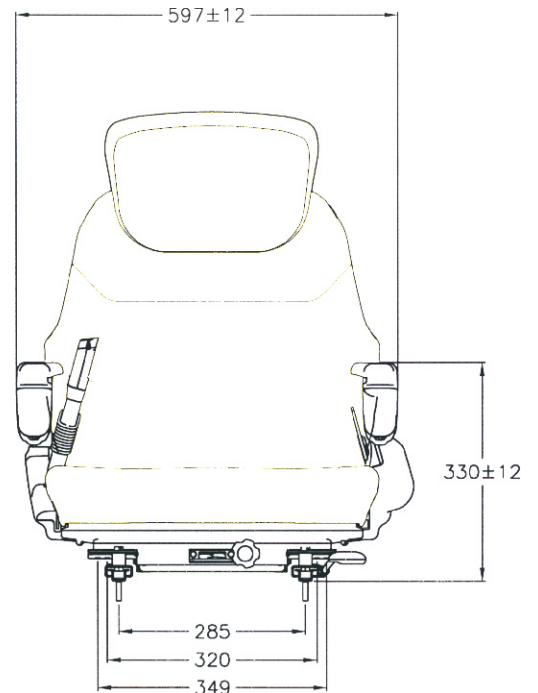
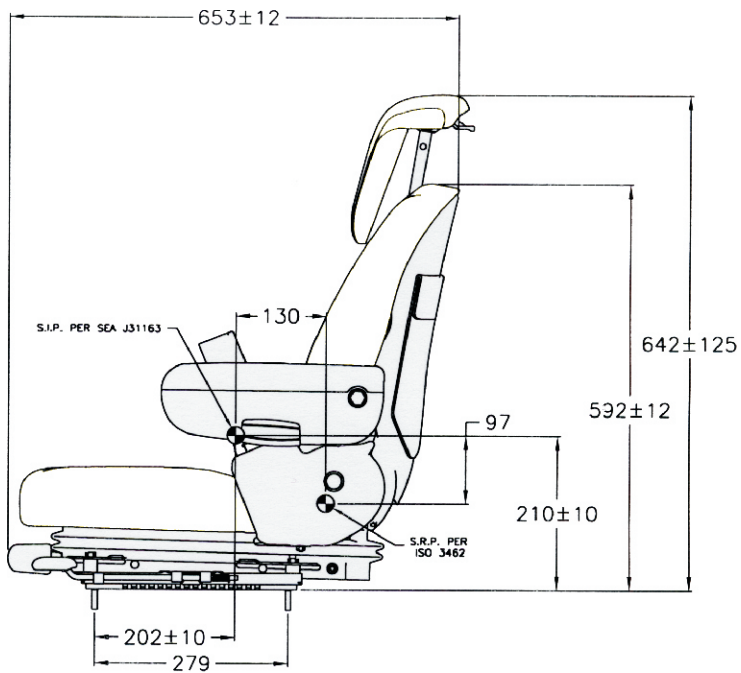

Low profile Torsion™ spring full mechanical suspension

#### FEATURES

Replaceable double depth Fabriform® comfort cushions  
Back angle fully adjustable  
Weight adjustment 30-130kg  
Suspension stroke 60mm  
Slide travel 160mm  
Moulded suspension cover  
Vibration performance to ISO 7096

#### OPTIONS

Armrests angle adjustable & tilt up.  
Hip restraints  
Electric air lumbar  
Mechanical Lumbar  
Upper back rest  
Seat belt to ISO 6683  
Swivel 15°-15°  
Hydraulic Damper  
Seat heaters 12, 24, 48v  
Operator presence switch  
Range of fabric, velour or PVC trim

Sears Manufacturing Co.(Europe) Ltd  
Unit 42, Rassau Industrial Estate,  
Ebbw Vale, Gwent NP23 5SD.  
United Kingdom  
Tel. 0044(0) 1495 304518  
Fax. 0044(0) 1495 304452  
Email: infouk@searsseating.com  
www.searsseating.com

