

Meet the seat that's tougher than the job your trucks perform.

Patented Fabriform® process makes Atlas cushions
virtually indestructible

Exceptional durability backed by the best cushion
warranty in the industry





Discover what makes Atlas the “ultimate” in comfort, durability and serviceability.

Atlas was designed with operator input

Why does Atlas excel?

The answer starts with extensive research conducted over two years. We obtained 16 different anthropomorphic measurements from nearly 200 male and female drivers to determine ideal seat contours and dimensions. We also surveyed drivers, OEMs, fleet operators and dealers to determine their requirements and feature preferences.

Then our engineers went to work designing these comfort advantages into Atlas seats for unmatched driver satisfaction and retention:

Improved Operator Comfort and Adjustability

Comfort Zone™ Support Structure

This exclusive feature consists of a magnesium back pan that’s contoured to the natural shape of the spine to provide full body support through the back region, and a contoured metal seat pan that fully supports the 22”-wide ergonomic cushions.

The seat cushion has three inches of foam on the centerline to help ensure maximum comfort and support. The back cushion provides contoured lumbar support.

Compare our sturdy structure to the competition’s tube frames:



Comfort Zone™ support structure is stronger.

Independent seat tilt and independent seat extension

This unique feature allows the driver to adjust the seat angle and seat length independently of each other for a more customized fit (available on 70 Premium Comfort and Elite 80).



Other features that make Atlas the “ultimate:”

- Seat-mounted controls are visible while seated.
- Height-adjustable air lumbar system is positioned to avoid direct pressure on the spine (available on 70 Premium Comfort and Elite 80).
- Wide armrests are easier to adjust.



Competitive frames are flimsy.



Unmatched Durability and Ride Performance

ToggleLink™ Air Suspension

Sears Seating improved truck seating from the ground up with a new patented design. The ToggleLink™ suspension delivers the better ride performance that drivers requested. Its internal end stops greatly reduce the chance of topping and bottoming, while the design's superior lateral stability reduces side-to-side rocking.

Atlas ToggleLink™ suspension also has fewer main wear points for longer service life.

Stabilizer double-locking slides/isolator

Sears added a double-locking slide/isolator package to further reduce vibration, eliminate torsion racking and greatly improve the ride. It allows for greater adjustability with 9" of fore/aft slide travel and a full two inches of smooth isolation.

Proof of Performance

Atlas was subjected to complete and rigorous durability testing. For the standard vertical bounce test, the seat carried a 280-pound weight for over 10 million vertical bounce cycles, while competition ranged from 1.7 million cycles to 3.3 million before failure.

Atlas excels in tests against others:

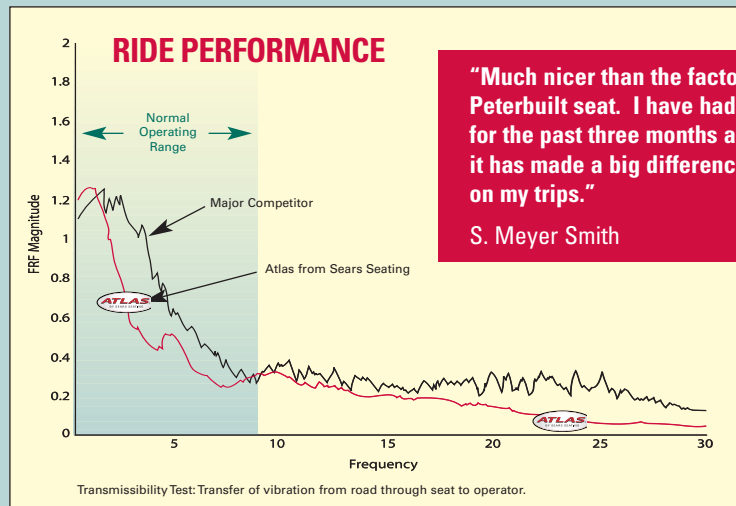
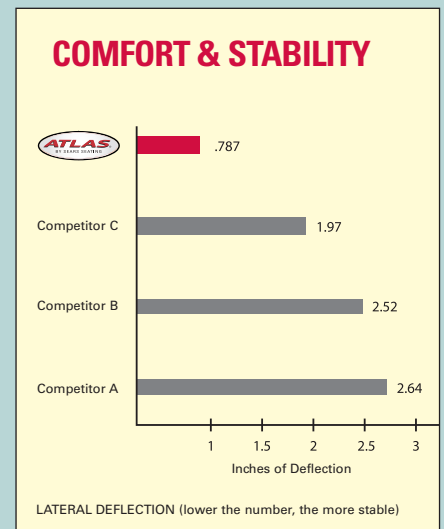
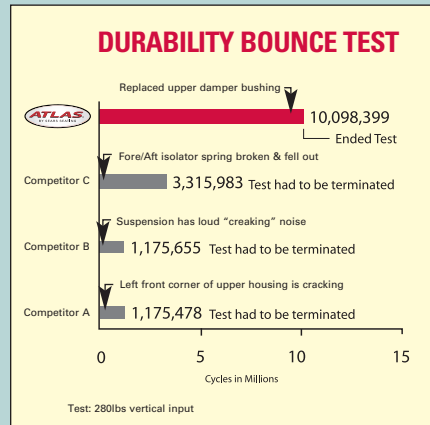

"Much nicer than the factory Peterbuilt seat. I have had it for the past three months and it has made a big difference on my trips."
S. Meyer Smith

"FIRST CLASS" IN SERVICEABILITY

FACT: Atlas provides easy maintenance and service to main wear points while in the vehicle.

- Atlas ToggleLink™ Suspension service/replacement:
 - Air Spring..... 20 min.
 - Shock absorber..... 20 min.
 - Suspension bearing-rear toggle..... 20 min.
 - Suspension bearing-front lower toggle..... 15 min.
 - Suspension bearing-front upper toggle..... 20 min.
 - Suspension upper rollers..... 30 min.
- Atlas Comfort Zone™ seat top
 - Seat air valves..... 20 min.
 - Back seat cover..... 50 min.

Elite 80 Series



Standard Features

- Exclusive Comfort Zone™ Support Structure
 - 22" Ergonomic "luxury style" cushions
 - High-back
 - Independent seat tilt
 - Independent seat extension
 - Recline
 - Height adjustable air lumbar
- Patented ToggleLink™ Air Suspension
 - Vinyl suspension skirt
- Stabilizer slide/isolator

Options

- Cloth or Ultraleather upholstery
- Armrests

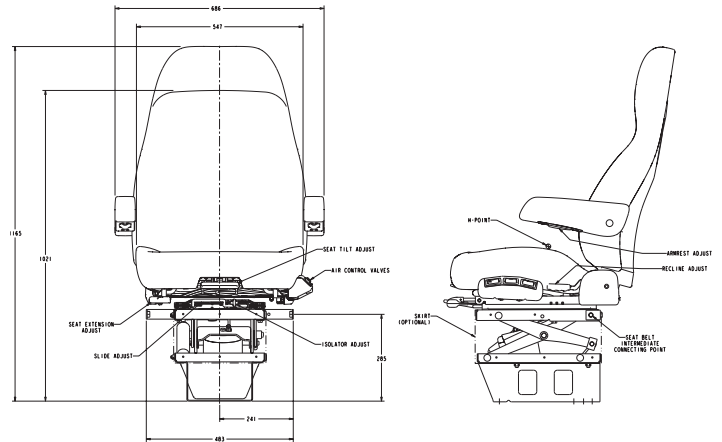

70 Series



Standard Features

- Exclusive Comfort Zone™ Support Structure
 - 22" Ergonomic "luxury style" cushions
 - Intergrated seat tilt/extension
 - Recline
 - Air lumbar
- Patented ToggleLink™ Air Suspension
- Stabilizer slide/isolator

Options

- Premium Comfort Package
 - Independent seat tilt
 - Independent seat extension
 - Height adjustable air lumbar
- Cloth or Ultraleather upholstery
- High-back or Mid-high back
- Vinyl or cloth upholstery
- Armrests
- Vinyl suspension skirt

35 Series



Standard Features

- Contoured seat pan w/ tube frame back support
 - 21" Ergonomic contoured cushions
 - Intergrated seat tilt/extension
 - Fixed lumbar
- Patented ToggleLink™ Air Suspension
- Double locking slides

Options

- Plus Comfort Package
 - Mechanical lumbar
 - Fore/aft isolator
- High-back or Mid-high back
 - Vinyl or cloth upholstery
 - Cloth Fabriform® cushions
- Armrests

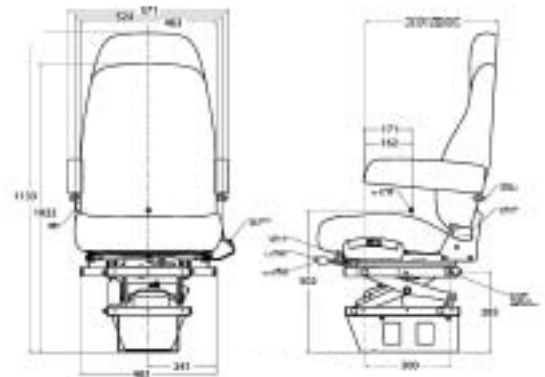

ATLAS SEATS ARE AVAILABLE IN OEM FABRICS

The old screwdriver-in-the-back-pocket abuse test barely leaves a mark.

Think how many times a day your operators are in and out of the cab. It adds up to hundred of thousands of times over the life of your truck. And every time someone slides in or out, your seats can pay the price with wear and tear.

You'll never have to worry about Atlas seats with Fabriform® wearing out. They're made of a patented process that flamebonds a trilaminate of film, foam and fabric.

We have enough confidence in the durability of our Fabriform® cushions to warrant them for five years.

The tri-laminate material provides a barrier of protection. Its "wicking" action disperses moisture and perspiration. The seats can be easily cleaned. They can even be hosed off!

The patented Fabriform® process involves flame-bonding a rugged tri-laminate of film, foam and fabric. Poured into the fabric/mold, the foam bonds with the tri-laminate fabric as it cures.

Superior wear-resistance makes Fabriform® ideal for dump, cement and regional delivery applications where drivers are in and out of the seat frequently. Also great for long-haul usage.



"We find the durability and comfort of Sears seats add value to our trucks. We use Sears seats whenever possible. The Fabriform® seat covers, along with the five-year warranty are an extra value."

Unlike cut-'n'-sew covers, Fabriform® cushions have no seams. This makes them impervious to dust, dirt and water — the major causes of cushion wear.

Timothy R. Trom
McNeilus Truck & Manufacturing Co.— Vehicle Administrator

Comfort

Comfort Zone™ full contoured support structure

- More support
- Greater driver comfort

Correct size, dimensions, and contours

- Meet drivers' needs
- Greater driver comfort

Contoured lumbar support

- Relief in spinal area
- Greater driver comfort
- Reduces fatigue

Wider and longer armrests

w/ front controls

- More comfort
- Easier to adjust

Seat mounted controls

- Easy to adjust
- Ergonomically correct

Isolator with 2 inch motion

- Reduces vibration
- Improves ride

Adjustability

Seat extension

- 1.5 inch adjustment
- Three positions
- More comfort and fit

Seat angle adjust

- Three (3) positions
- Five degrees of adjustment

Steel risers with multiple mounts

- Adaptability to fit more applications
- Simplifies OEM, fleet, supplier programs

Height adjustable lumbar

- Multi-chamber for support
- Comfort

Infinite Recline

- Range of adjustment

Durability

New ToggleLink™

Suspension design

- Improved lateral stability
- Improved fore/aft stability
- Superior ride performance
- Greater driver comfort

9 inch double-locking slides

- More range of adjustment
- Eliminates torsion racking
- Improved safety pull test performance

Warranty

Sears Stands By Its Seats

Sears Seating expressly warrants to the original purchaser that all suspension seats shall be free from defects in materials and workmanship for 10 years from date of purchase.

Sears' exclusive Fabriform® cushions are also warranted against defects in material for a period of 5 years, excluding normal wear and tear.

All sewn cushions and seat covers shall be free from defectively sewn seams for a period of 1 year or 100,000 miles, whichever comes first, excluding normal wear and tear.

For other details on our warranty policy, contact your Sears Seating representative or Sears Seating Customer Service. 800-553-3103.

